



MULTIBLAST
PERFORMANCE BLASTING

OPERATING MANUAL

Operating Manual Rev Mar. 2021	MODEL	MultiBlast PRO 45 20Litre
-----------------------------------	-------	------------------------------

Section	Description
1	Important Information
2	How The System Works
3	Initial Set Up
4	Operation
5	Shut Down And Storage
6	Preventative Maintenance
7	Troubleshooting
8	Parts Listing
8.1	Bare Pot Assembly
8.2	Pot Package A
8.3	Auto Exhaust Piping Assembly
8.4	Air Control Valve Assembly
8.5	Air Control Valve Service Kit
8.6	Exhaust Valve Assembly
8.7	Exhaust Valve & Muffler Assembly
8.8	Exhaust Muffler Assembly
8.9	Exhaust Control Line Assembly
8.10	Pusher Line Assembly
8.11	Micro Valve Assembly
8.12	Micro Valve Service Kits
8.13	Twinline Hose Assembly
8.14	Moisture Trap Assembly
8.15	Deadman Handle Assembly



WARNING – Do not operate this equipment without reading and understanding the contents of this manual.

BLAST POT EASY SELECTION GUIDE

Description	Performance Blast Pots					
	MultiBlast PRO16	MultiBlast PRO45	MultiBlast PRO90	MultiBlast PRO180	MultiBlast PRO340	MultiBlast PRO400
Model						
Volume (Liters)	7	20	40	80	140	174
Garnet Capacity (kg)	16	45	90	180	320	400
Dimensions - Height (mm)	890	575	880	1010	1310	1320
Dimensions - Diameter (mm)	150	290	290	508	508	610
Piping Diameter (mm)	15	15	25	32	32	32
Mini Micro Valve	✓	✓				
Micro Feed Valve 11/4" (32 NB)			✓	✓	✓	✓
Micro Feed Valve 11/2" (40 NB)						
Small Urethane Pop Up Valve	✓	✓	✓			
Large Urethane Pop Up Valve				✓	✓	✓
Lid and Screen Set		✓	✓	✓	✓	
Moisture Separator (mm)		15	25	40	40	40
Blast helmet - Nova 2000	✓	✓	✓	✓	✓	✓
Blast helmet Air Supply Hose	✓	10m	10m	20m	20m	20m
Blast Hose Standard 1/2" (12.5mm) x 27mm OD	5m	10m				
Blast Hose Standard 3/4" (20mm) x 34mm OD			10m			
Blast Hose Standard 1" (25mm) x 40mm OD				20m		
Blast Hose Standard 1 1/4" (32mm) x 48mm OD					20m	20m

Pressure Blast Nozzle Data

Nozzle Orifice	Pressure At The Blast						Air, Power and Abrasive Required
	60	70	80	90	100	125	
No.2 1/8" (3.2mm)	12	15	17	18.5	20	25	Air (CFM)
	35	40	46	51	56	69	Abrasive (kg/hr)
	3	3.5	4	4.5	5	5.5	Compressor (hp)
No.3 3/16" (4.8mm)	30	33	38 98	41	45	55	Air (CFM)
	77	89	9	108	120	145	Abrasive (kg/hr)
	7	8		10	10	12	Compressor (hp)
No.4 1/4" (6.4mm)	54	61	68	74	81	98	Air (CFM)
	142	161	185		224	276	Abrasive (kg/hr)
	12	14	16	203 17	18	22	Compressor (hp)
No.5 5/16" (8mm)	89	101	113	126	137	168	Air (CFM)
	242	274	305	336	369	446	Abrasive (kg/hr)
	20	23	26	28	31	37	Compressor (hp)
No.6 3/8" (9.5mm)	126	143	161	173	196	237	Air (CFM)
	347		436	478	523	633	Abrasive (kg/hr)
	28	392 32	36	39	44	52	Compressor (hp)
No.7 7/16" (11mm)	170	194	217	240	254	314	Air (CFM)
	469	534	596	658	720	877	Abrasive (kg/hr)
	38	44	49	54	57	69	Compressor (hp)



**IMPORTANT – READ THIS INFORMATION CAREFULLY
PRIOR TO OPERATING THE EQUIPMENT.
ALL ABRASIVE BLASTING OPERATIONS ARE
DANGEROUS AND CREATE A HAZARDOUS
ENVIRONMENT.
FAILURE TO COMPLY WITH THIS INFORMATION MAY
CAUSE SERIOUS INJURY OR DEATH.**

Section 1.0 Important Information

1.1 All products and equipment designed and manufactured are intended for use by experienced users of abrasive blasting equipment, and its associated operations and abrasive blasting media.

1.2 It is the responsibility of the user/purchaser/distributor to:

1.2.1 Determine if the equipment and abrasive media is suitable for the user's intended use and application.

1.2.2 Familiarize yourself with any appropriate laws, regulations and safe working practices which may apply within the user's working area/environment.

1.2.3 Provide appropriate operator training and a safe working environment, including operator protective equipment such as, but not limited to, safety footwear, protective eyewear, hearing protection, and respiratory protection where applicable.

1.3 No representations are made or intended as to the useful life, maintenance cycles, efficiency or performance of the reference products or any combination of products.

1.4 Information contained herein must not be used for estimating purposes. Production rates, labor performance and surface finishes are the sole responsibility of the user.

1.5 Read all instructions carefully prior to operating this equipment, and do not allow it to be operated by inexperienced, untrained or unauthorized personnel.

1.6 Ensure that the equipment is correctly serviced and maintained as specified in this manual, and that only genuine replacement parts are utilized. Failure to use genuine replacement parts may void your warranty.

1.7 All pressure vessels (where supplied) are designed, manufactured and certified in accordance with Australian Standard AS1210. A copy of this certification will be supplied with this manual if applicable. Do not weld, grind or drill any

pressure vessel, as this will void the certification and warranty, and may weaken the vessel causing a catastrophic failure.

1.8 This equipment is not designed for use in areas designated as hazardous. Contact your local representative prior to operating this equipment in a hazardous area.

1.9 All compressed air fittings, connections and hoses must be in good condition, fit for purpose, correctly sized and fitted, and carefully inspected prior to use.

1.10 Breathing airborne dust from any abrasive media may cause lung disease or other serious injury. Always wear suitably designed respiratory protection when handling any abrasive media, and when in the immediate area during any abrasive blasting operation.

1.11 Static electricity may be generated during any abrasive blasting operation. All equipment should be well grounded/earthed to prevent electric shock and reduce the risk of spark generation.

1.12 All Supplied Air Respirators (i.e.: blasting helmets) where used must comply with the requirements of AS/NZS 1716:2003, and must be supplied with breathing air as specified in AS/NZS 1715:2009 or higher, at a flow rate between 170l per minute (6cfm) and 425l per minute (15cfm) at all times, depending on the number of operators.

Section 2.0 How The Auto Exhaust System Works

2.1 When the compressed air supply is connected to the blast pot, and the supply ball valve is opened, the air supply passes through the water trap and stops at the air control valve which is closed. The air will also travel down the input side of the twinline hose, as far as the deadman handle, which is also closed.

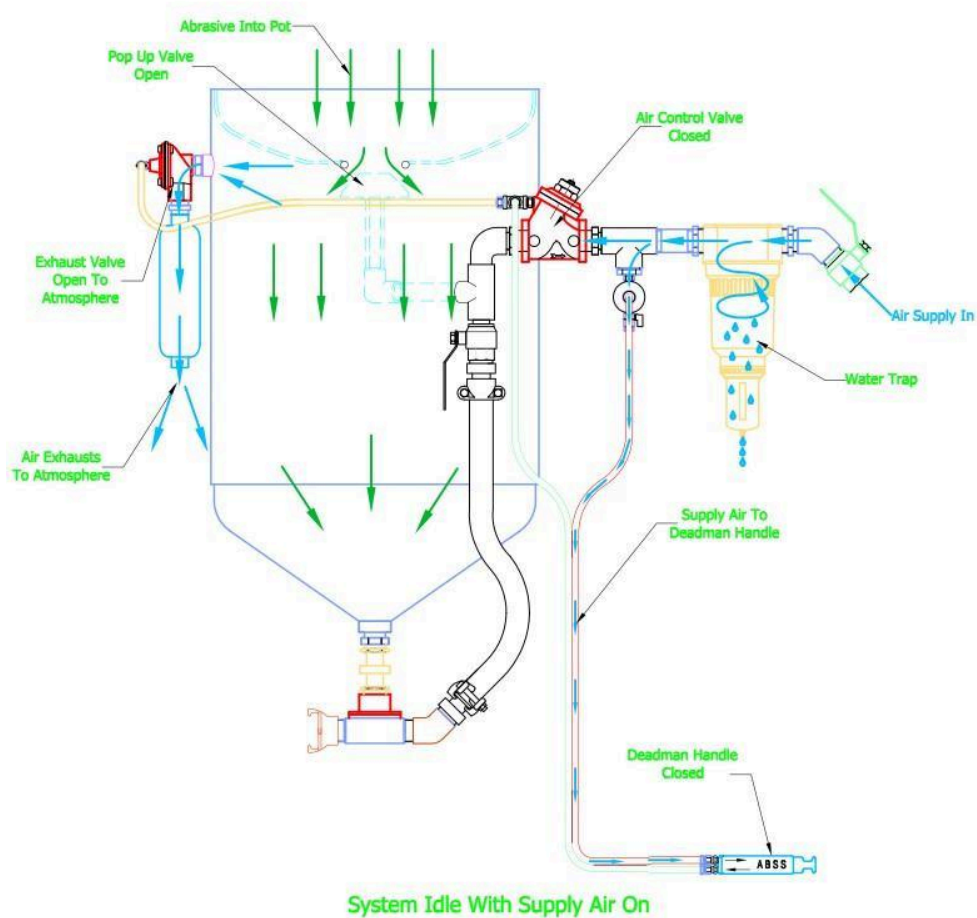

2.2 When the operator depresses the deadman handle, the signal air in the twinline passes through the deadman handle, and down the return side of the twinline hose, simultaneously sending signal air to both the Air Control Valve, which then opens, and the Exhaust Valve, which then closes.

2.3 The air supply then enters the blast pot, which lifts the pop up valve, and allows the pot to pressurise. At the same time, compressed air also enters the pusher line, mixing with the abrasive media which has now commenced flowing from the pot, within the Micro Abrasive Valve. The system is now in blasting mode.

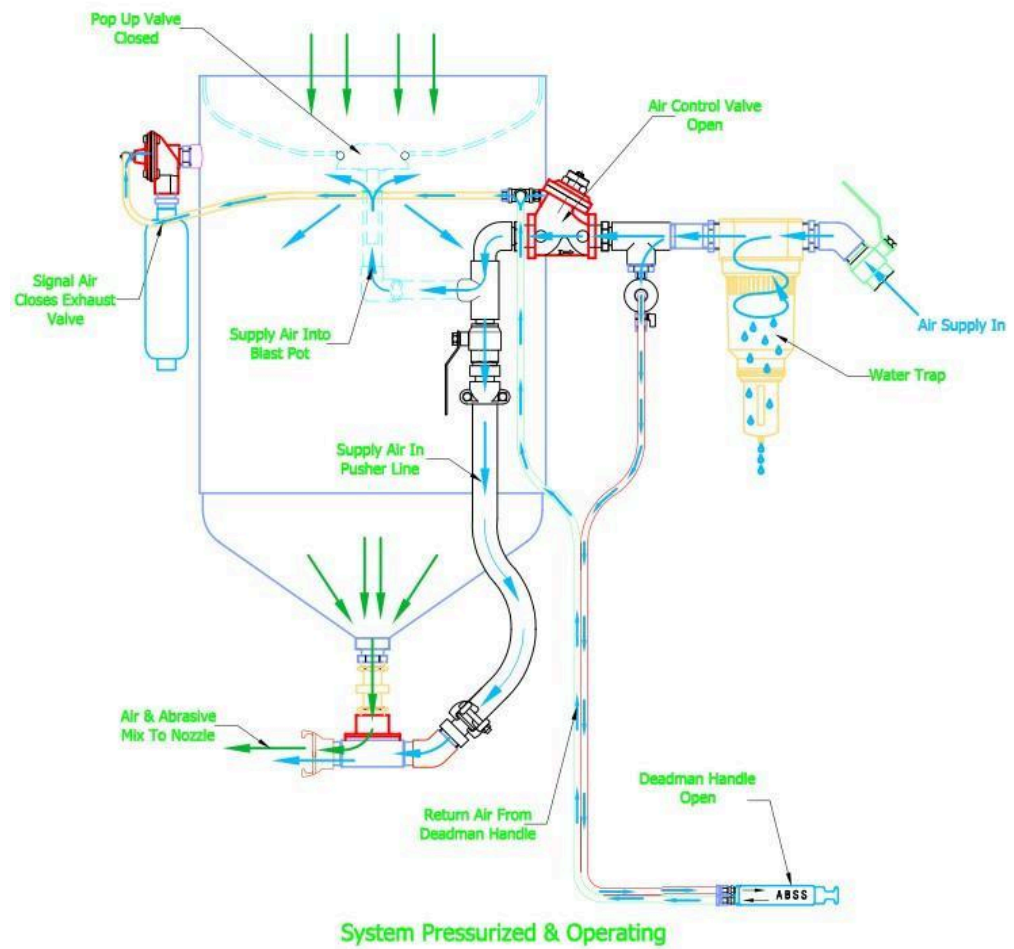

2.4 When the operator releases the deadman handle to stop blasting, the signal air to both the Air Control Valve and the Exhaust Valve is stopped, closing the Air Control Valve and opening the Exhaust Valve. This depressurises the pot, allowing the pop up valve to open, which in turn allows the pot to be refilled with abrasive media.

Section 3.0 Initial Set Up

3.1 Ensure the blast pot is in a stable position on a flat level surface, directly adjacent to the work area.

3.2 Uncoil the twinline hose and deadman handle assembly, and lay it out on a flat surface for its full length.

3.3 Uncoil the blast hose assembly, and lay it out for its full length directly adjacent to the uncoiled twinline assembly.

3.4 Position the deadman handle on the blast hose directly behind the nozzle holder, and attach the deadman handle to the blast hose using the two (2) cable ties provided. Ensure the handle is firmly attached, and trim the ends of the cable ties as short as possible.

3.5 Attach the twinline hose to the blast hose using cable ties/tape or similar, locating the ties/tape at approximately 1m to 1.5m intervals along the hose length, and as close to the hose coupling as possible.

3.6 The twinline hose should extend approximately 2m longer than the blast hose length at the coupling end.

3.7 Connect the blast hose coupling to the Micro Valve coupling, first checking that the coupling gaskets are correctly seated and are not worn. Check that the safety clip holes in the couplings align correctly, and that the safety clip itself is correctly fitted and prevents the coupling from inadvertently disconnecting.

3.8 Connect the two (2) loose ends of the twinline assembly to the blast control system by pushing the fittings directly together. The male end of the twinline connects to the female fitting located on the manifold block, and the female end connects to the male fitting located in the tee fitting directly adjacent to the Air Control Valve.

(Note: The twinline hose fittings use a dual action connection to prevent accidental disconnection. To disconnect the twinline fittings, first push the fittings inwards together, then pull back the outer sleeve on the female fitting. This will then allow the fittings to disconnect.)

3.9 Connect a suitably sized compressed air hose to the blast pot inlet ball valve using correctly fitted and sized compressed air fittings which feature a safety pin locking system. It is recommended the compressed air supply line be one size larger than the blast pot piping. For example, a pot with 1 ¼" piping should be connected to a 1 ½" supply line.

3.10 At this point, ensure that the pot air supply ball valve is in the closed position.

3.11 Connect the operator breathing air supply hose to the claw coupling ensuring at this point the ball valve is closed.

(Note: Refer to Section 1.12 of this manual for minimum breathing air quality requirements)

3.12 The blast pot is now ready for operation.

Section 4.0 Operation



WARNING: THE INITIAL OPERATION AND ADJUSTMENT OF THE BLAST POT REQUIRES TWO (2) PERSONS, THE BLASTING OPERATOR AND AN ASSISTANT. UNDER NO CIRCUMSTANCES SHOULD THE BLASTING OPERATOR ATTEMPT TO CARRY OUT ANY ADJUSTMENTS WHILE CONTROLLING THE BLASTING NOZZLE.

4.1 The following items must be carefully checked prior to commencing operation of the blast pot –

- 4.1.1 The pot has been correctly set up as specified in Section 2.0 of this manual.
- 4.1.2 The compressed air supply hose is securely attached to the blast pot inlet, and that the safety pins/clips are correctly fitted.
- 4.1.3 The air compressor outlet valve must be closed.
- 4.1.4 The blast pot inlet valve must be closed.
- 4.1.5 The breathing air ball valve must be closed.
- 4.1.6 Turn the control knob on the Mini Micro Abrasive Valve clockwise until fully closed.
- 4.1.7 Check that the deadman control handle's safety latch moves freely and prevents the handle from accidental activation.
- 4.1.8 Carefully inspect the blast hose, hose fittings and blast nozzle for excessive wear and or damage. Replace worn/damaged components as necessary.
- 4.1.9 Carefully inspect the blast operators' blast helmet, breathing air filters and breathing airlines to ensure that they are in good working order, and comply

with the requirements as specified in Section 1.12 of this manual. Replace worn/damaged components as necessary.

4.2 Inspect the abrasive to be used, and ensure that it is clean, dry and flows easily. Damp abrasive will tend to clog the blasting system, and prevent it from operating correctly.

4.3 Fill the blast pot with the abrasive through the pop up valve opening located in the top of the pot, being careful not to over fill. The entire domed area of the pop up valve must be clearly visible after filling the blast pot.

4.4 Turn on the air compressor, and bring it up to operating pressure and temperature in accordance with the manufacturer's instructions. The minimum compressed air pressure for the blast pot to activate correctly is 3.4Bar (50psi).



WARNING: NEVER EXCEED THE PRESSURE VESSELS MAXIMUM PRESSURE RATING OF 8.6Bar (125psi) AS SHOWN ON THE PRESSURE GAUGE ATTACHED TO THE BLAST POT.

4.5 Slowly fully open the compressor outlet valve, and check the air supply line to the pot for leaks. If any leaks are apparent, shut down the compressor, bleed the pressure from the system, and repair any leaks.

4.6 Slowly fully open the blast pot inlet valve. The pot piping is now under pressure up to the Air Control Valve, as well as the out-going signal line (green) of the twinline to the deadman handle. Check the pressurised part of the control system for air leaks, and repair as necessary.

4.7 Open the ball valve to provide airflow to the operator's blasting helmet, via the breathing air filters. (Refer Section 1.12 for further information).

4.8 The operator should now don the appropriate protective equipment, such as a blast suit, hearing protection, blasting helmet and leather gloves.

4.9 It is also strongly recommended that the assistant also wear hearing and eye protection.

4.9 Ensure that the areas' directly around the blast pot and the blast pot operator are clear of all personnel.

4.10 The operator now depresses the deadman control handle, which will send the return signal to open the Air Control Valve and close the Exhaust Valve. This allows high pressure air to enter the pressure vessel, lifting the pop up valve and pressurising the vessel.



WARNING: HIGH PRESSURE COMPRESSED AIR EXITING THE BLAST NOZZLE WILL GENERATE EXTREMELY HIGH LEVELS OF NOISE. IT IS STRONGLY RECOMMENDED THAT THE BLASTING OPERATOR, ASSISTANT, AND ANY OTHER PERSONNEL WITHIN THE IMMEDIATE VICINITY SHOULD WEAR APPROPRIATE HEARING PROTECTION.

4.11 After a slight delay, high pressure air will commence flowing from the blast nozzle. The assistant slowly open the Micro Abrasive Valve by turning the control knob anticlockwise, until the operator signals that the desired abrasive media flow has been achieved.

4.12 Optimum abrasive flow is dependent upon abrasive type and size and blasting pressure, and can best be determined by operator experience. As a general rule, the operator should attempt to use the minimum amount of abrasive flow to achieve the

fastest cleaning rate. It is normal for the airstream exiting the blast nozzle to be only slightly discoloured by the abrasive within the airstream.

4.13 To cease blasting, the operator simply releases the deadman control handle lever, which will de-energise the Air Control Valve and the Exhaust Valve, which in turn allows the pot vessel to de-pressurise and vent the internal compressed air out through the exhaust pipe.

Section 5.0 Shutdown & Storage

- 5.1 When operating in environments subject to varying temperature changes, or in high humidity, it is possible for condensation to form inside the pressure vessel. This condensation will dampen the abrasive, causing problems with the blast pot operation. It is recommended that the blast pot be emptied of abrasive at the end of each day to minimise this problem.
- 5.2 With the blast pot turned off, reduce the blast pressure down to approximately 275 – 350 Kpa (40-50psi), close the choke valve in the pusher line, and fully open the Micro Abrasive Valve.
- 5.3 Direct the blast nozzle into a drum/container, or towards the location where the abrasive is to be disposed of.
- 5.4 Hold the hose securely, and activate the blast system by closing the deadman handle. The blast hose will surge and recoil quite abruptly as the abrasive is forced out of the blast pot.
- 5.5 Once the blast pot has emptied, release the deadman handle to depressurise the blast pot. Open the choke valve, and note that the abrasive valve will need to be re-adjusted for blasting operations.
- 5.6 Close the air inlet valve on the blast pot, close the compressor air supply valve, and shutdown the air compressor.
- 5.7 Drain all compressor receivers, filters and water traps in accordance with the compressor manufacturer's instructions, and bleed all air from the airlines.
- 5.8 Cover the blast pot when not in use.

Section 6.0 Preventative Maintenance

6.1 **Daily Inspections.** With the compressed air turn off, carry out the following daily inspections:

6.1.1 Drain any moisture from the Water Trap and inspect the internal element. Clean or replace as necessary.

6.1.2 Inspect the blast hose for wear. Look for visual damage, and squeeze along the full length of the hose feeling for soft spots. A soft spot indicates wear, and the hose should be replaced.

6.1.3 Check the hose coupling and nozzle holder, ensuring there is no sign of air leakage, and that the lock pins are correctly fitted and securely in place. Ensure that all retaining screws are securely in place.

6.1.4 Remove the blast nozzle from the nozzle holder and check the condition of the nozzle washer. The washer should be replaced if it shows any sign of wear or damage.

6.1.5 Carefully inspect the condition of the deadman handle, and ensure that the lever lock operates smoothly, and prevents the handle from accidental operation. The lever must not touch the valve plunger unless the lever lock is down and the handle fully depressed. The handle lever must fully return to the up position when released.

During blasting, have the blasting assistant do the following on a daily basis.

6.1.6 Check the control handle and twinline for leaks.

6.1.7 Check all couplings and coupling gaskets for leaks.

6.1.8 Check the nozzle holder and nozzle washer for leaks.

6.1.9 Carefully inspect the blast pot for leaks. If leaks are found around the pop up valve, top flange or fitting on the bottom of the pot cone, stop blasting immediately and carry out the necessary repairs. Failure to do so may cause irreparable damage to the blast machine.

6.2 **Weekly Inspections.** With the compressed air turned off, carry out the following on a weekly basis:

6.2.1 Remove the blast nozzle from the nozzle holder, and inspect the nozzle for wear/damage. Replace the nozzle if it is worn more than 1.5mm from its original size, or if the liner is grooved or cracked.

6.2.2 Carefully inspect the nozzle and nozzle holder threads for wear/damage. It is vital that the blast nozzle screws fully into place and seals

firmly against the nozzle washer to prevent leaks and damage to the nozzle and nozzle holder.

6.2.3 Visually inspect the Mini Micro Abrasive Valve for any signs of wear, paying particular attention to the threaded section of the steel pipe nipple. Replace the pipe nipple at the first sign of wear and/or leakage.

During blasting, note the following:

6.2.4 Monitor the time taken for the blast pot to fully depressurise after deactivation. If the time has increased noticeably, check the exhaust pipe/muffler for damage and/or restrictions.

6.3 **Monthly Inspections.** With the compressed air turned off, carry out the following:

6.3.1 Check the condition of the pop up valves' mushroom head, and ensure that it is not worn or grooved. The pop up valve should be replaced at the first sign of significant wear.

6.3.2 Inspect the rubber pop up valve seal located in the top flange. Check that the seal is not dried out, cracked or worn, and that the seal is seated correctly within the flange. Replace the seal at the first sign of significant wear.

6.3.3 Remove the Mini Micro Abrasive Valve by unscrewing it from the blast pot. Dismantle the Mini Micro Valve, and carefully inspect the hardened steel plunger and urethane sleeve for damage or wear. Replace items as necessary.

6.3.4 Carefully inspect the internal section of the tee piece for wear, paying particular attention to the threaded ends. Replace the tee piece if it appears worn or grooved.

Section 7.0 Troubleshooting

Problem	Possible Cause/Remedy
No abrasive or air from the blast nozzle while the blast pot is pressurised.	<p>Depressurise the blast pot, and after the pop up valve has dropped, remove the blast nozzle and check for any obstruction.</p> <p>Check that both the Micro Abrasive Valve and the pusher line choke valve are open.</p>
Compressed air but no abrasive from the blast nozzle while the blast pot is pressurised	<p>Micro Abrasive Valve may be closed, and require adjustment. Refer Section 3.11</p> <p>No abrasive in the blast pot</p> <p>Abrasive may be damp, preventing proper flow. Clean the pot out and refill with dry abrasive. Drain all moisture from moisture traps.</p> <p>Check Mini Micro Abrasive Valve for obstructions.</p>
Heavy abrasive flow	<p>Mini Micro Abrasive Valve may be fully open, and require adjustment. Refer Section 3.11</p> <p>Check that the pusher line chock valve is open.</p>
Abrasive surging	<p>Note: Some surging is normal upon start up. Should the surging continue, adjust the Mini Micro Abrasive Vale as per Section 3.11.</p>
Blast Pot will not pressurise	<p>Check that the air compressor is operating, and all air supply lines are open.</p> <p>Check that the deadman handle lever is correctly depressing the handle plunger</p> <p>Inspect the twinline hose for leaks, and repair as necessary. Check that the twinline is securely connected at the blast pot.</p> <p>Check the deadman handle for air leaks with the lever depressed. No air should leak from the handle with the lever depressed.</p> <p>Inspect the exhaust control line for leaks between the Air Control Valve (Item 15) and the Exhaust Valve</p> <p>Dismantle the Exhaust Valve (and check the diaphragm for wear/holes/tears, and replace if necessary.</p> <p>Check that the pop up valve is not worn or out of alignment, and is seated correctly. Replace/adjust as necessary.</p>
Blast pot will not depressurise, or depressurises slowly	<p>Check the Exhaust Valve and exhaust piping for obstructions.</p> <p>Check that the return air on the twinline is exhausting air from the deadman handle around the plunger when the lever is released.</p>
Intermittent abrasive flow	<p>Abrasives may be damp, preventing proper flow. Clean the pot out and refill with dry abrasive. Drain all moisture from moisture traps.</p> <p>Excessive dust and fines in abrasives. Refill the blast pot with a new abrasive.</p>

Section 8.0 Replacement Parts
8.1 Basic Pot Shell Assembly

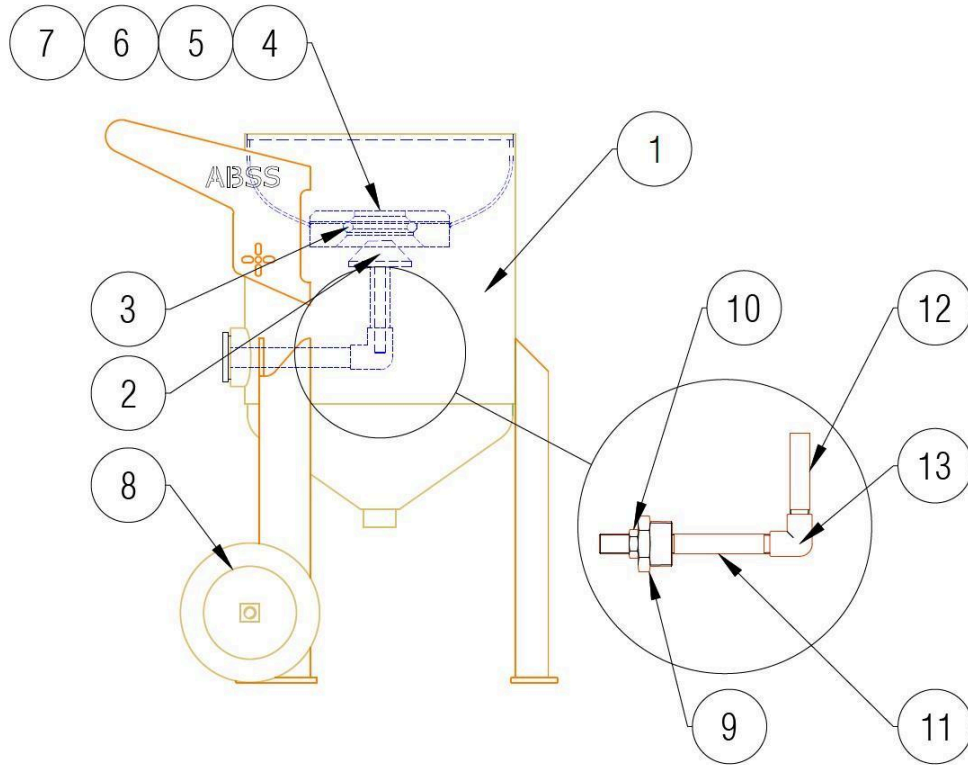

BARE POT ASSEMBLY

		MODEL	MultiBlast PRO 45
		ASSY NO.	
ITEM	DESCRIPTION	QTY	
1	BARE POT - SUB ASSEMBLY	1	
2	POP UP VALVE - SMALL	1	
3	O RING – SMALL	1	
4	RETAINING FLANGE - SMALL	1	
5	GASKET-FIBRE-50NB-TABLE E	1	
6	WASHER – FLAT – 16mm	4	
7	BOLT-HEX HEAD-M16 x 35mm	4	
8	WHEEL – 152mm DIAMETER	2	
9	BUSH-REDUCING-1 ½” BSP x ½” BSP	1	
10	BACKNUT – ½” BSP	1	
11	PIPE PIECE – ½” BSP - SPECIAL	1	
12	PIPE PIECE – ½” BSP	1	
13	ELBOW – STEEL – F & F – ½” BSP	1	

8.2 Pot Package A

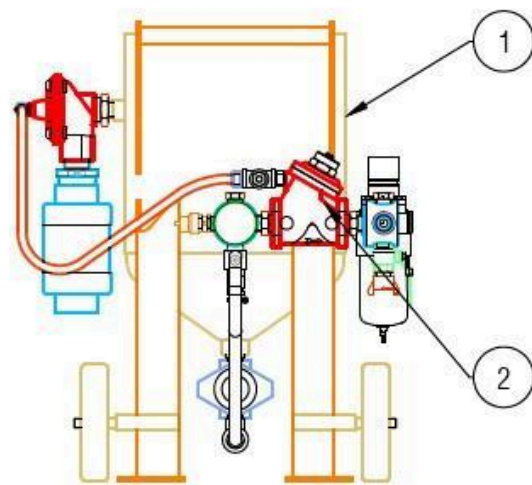
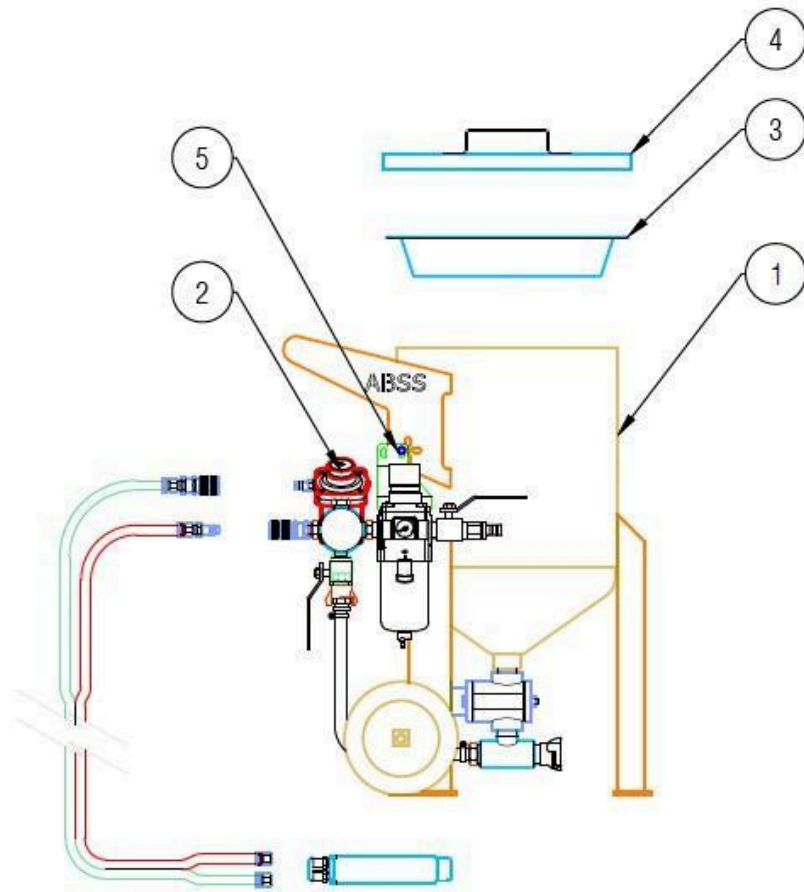

POT PACKAGE A

POT PACKAGE A		MODEL	MultiBlast PRO 45
		ASSY NO.	
ITEM	DESCRIPTION	QTY	
1	ASSEMBLY - BARE POT SHELL	1	
2	ASSY-AUTO EXHAUST PIPING-1" BSP	1	
3	LID	1	
4	SCREEN	1	
5	ASSY - PIPING SUPPORT BRACKET	1	

8.3 Auto Exhaust Piping Assembly

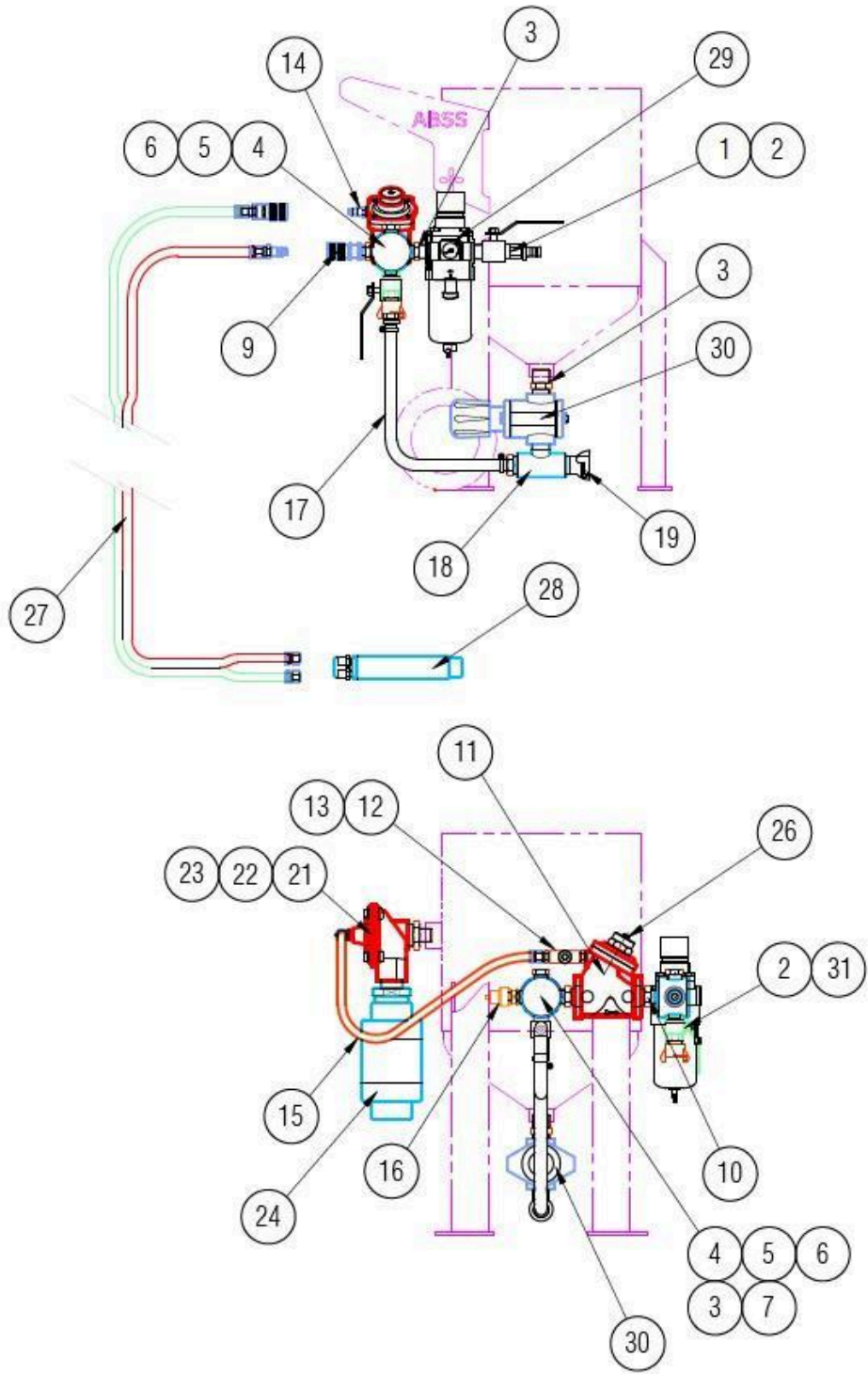

AUTO EXHAUST POT PIPING ASSEMBLY

		MODEL	MultiBlast PRO 45
		ASSY NO.	
ITEM	DESCRIPTION	QTY	
1	BARB – HOSE – ½” BSP x ½” HOSE	1	
2	VALVE – BALL – M & F – ½” BSP	3	
3	NIPPLE – ½” BSP	2	
4	MANIFOLD – 5 WAY	2	
5	PLUG – ½” BSP	2	
6	BUSH – REDUCING – ½” BSP x ¼” BSP	1	
7	BUSH – REDUCING – 1 ½” BSP x ½” BSP	1	
9	COUPLING – QUICK CONNECT – FEMALE	1	
10	NIPPLE – REDUCING – ¾” BSP x ½” BSP	2	
11	VALVE – AIR CONTROL – ¾”	1	
12	NIPPLE – ¼” BSP	2	
13	TEE – ¼” BSP	1	
14	COUPLING – QUICK CONNECT – MALE	1	
15	EXHAUST CONTROL LINE	1	
16	VALVE – PRESSURE RELIEF – 125PSI – ½” BSP	1	
17	PUSHER LINE KIT	1	
18	TEE – MINI MICRO – ¾” BSP	1	
19	COUPLING – CLAW – ¾” BSP	1	
21	ELBOW – M & M – ¼” BSP	1	
22	VALVE – EXHAUST – 1” BSP	1	
23	NIPPLE – REDUCING – 1” BSP x ½” BSP	1	
24	MUFFLER – SHORT	1	
26	BREATHER – BRONZE – 1/8” BSP	1	
27	TWINLINE HOSE ASSEMBLY – 12m	1	
28	DEADMAN HANDLE ASSEMBLY	1	
29	FILTER/REGUALTOR – ½” BSP	1	
30	VALVE – MINI MICRO – ¾” BSP	1	
31	COUPLING – CLAW – TYPE A – ½” BSP MALE	1	

8.4 Air Control Valve Assembly

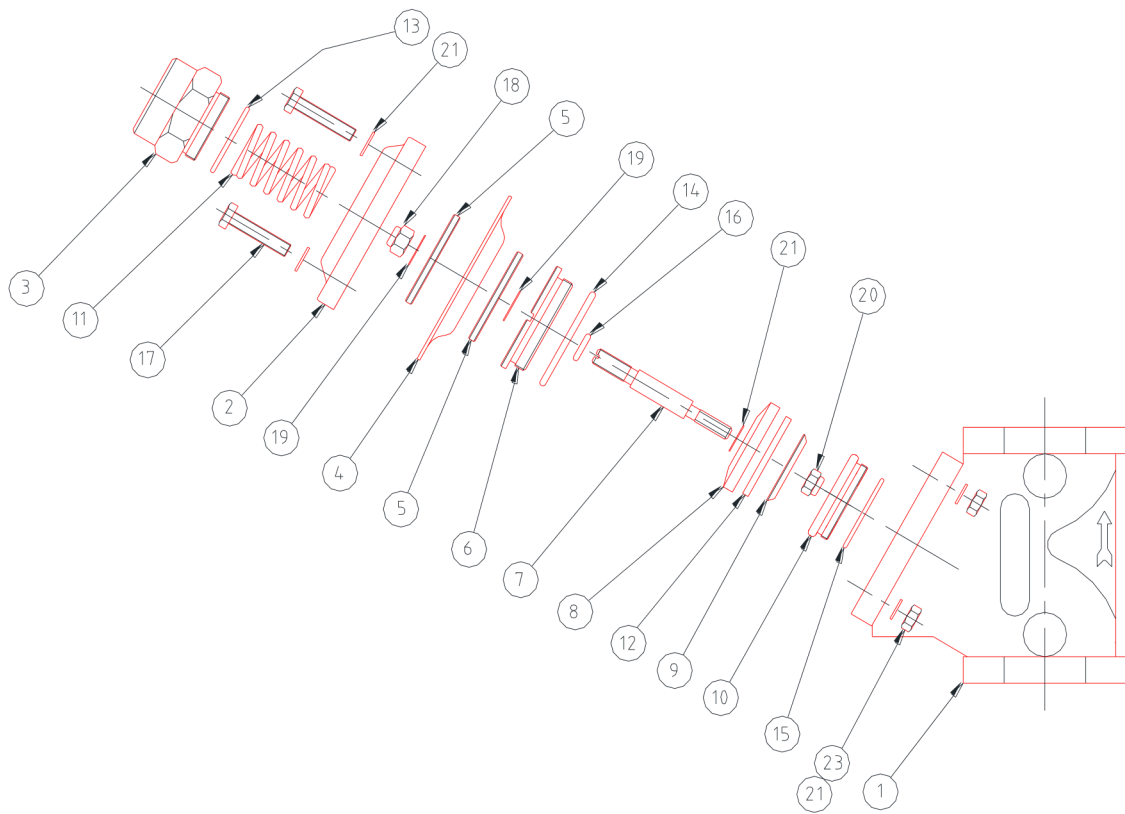

AUTO AIR VALVE – 3/4"		MODEL	MultiBlast PRO 45
		ASSY NO.	
ITEM	DESCRIPTION	QTY	
1	BODY - AIR CONTROL VALVE – 3/4"	1	
2	COVER - AIR CONTROL VALVE	1	
3	CAP - AIR CONTROL VALVE	1	
4	DIAPHRAGM - AIR CONTROL VALVE	1	
5	WASHER - FLAT	2	
6	BUSH - INNER	1	
7	SHAFT	1	
8	SEAT HOLDER	1	
9	RETAINER	1	
10	GUIDE - BUSH	1	
11	SPRING - AIR CONTROL VALVE	1	
12	GASKET	1	
13	O RING	1	
14	O RING	1	
15	O RING	1	
16	O RING	1	
17	BOLT-HEX HEAD-1/4" UNC X 1 1/2"	4	
18	NUT-NYLOC-5/16" UNF	1	
19	WASHER-FLAT-5/16" DIA X 0.5MM BRASS	1	
20	NUT-NYLOC-1/4" UNF-ZINC	1	
21	WASHER-FLAT-1/4" DIA-ZINC	8	
22	WASHER-FLAT-1/4" DIA X 0.5MM BRASS	1	
23	NUT-NYLOC-1/4" UNC-ZINC	4	

8.5 Air Control Valve Service Kit

SERVICE KIT-AUTO AIR VALVE-3/4"		MODEL	MultiBlast PRO 45
		ASSY NO.	
ITEM	DESCRIPTION	QTY	
4	DIAPHRAGM - AIR CONTROL VALVE	1	
12	GASKET	1	
13	O RING	1	
14	O RING	1	
15	O RING	1	
16	O RING	1	
19	WASHER-FLAT-5/16" DIA X 0.5MM BRASS	1	
20	NUT-NYLOC-1/4" UNF-ZINC	1	
22	WASHER-FLAT-1/4" DIA X 0.5MM BRASS	1	

8.6 Exhaust Valve

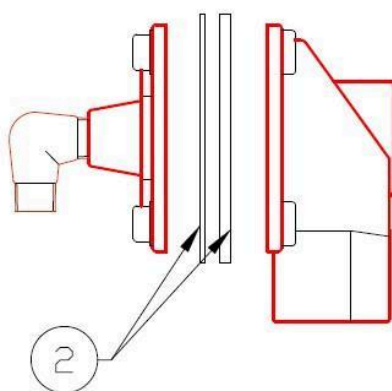
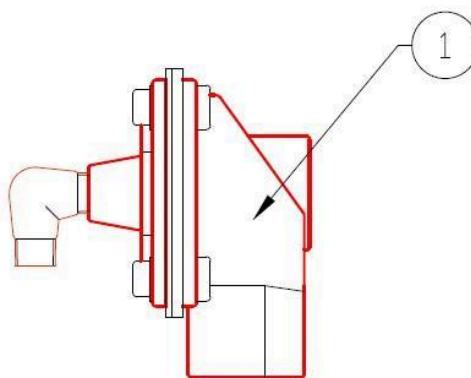

EXHAUST VALVE - 1"

		MODEL	MultiBlast PRO 45
		ASSY NO.	
ITEM	DESCRIPTION	QTY	
1	ASSY-EXHAUST VALVE-1"	1	
2	KIT - DIAPHRAGM	1	

8.9 Exhaust Control Line

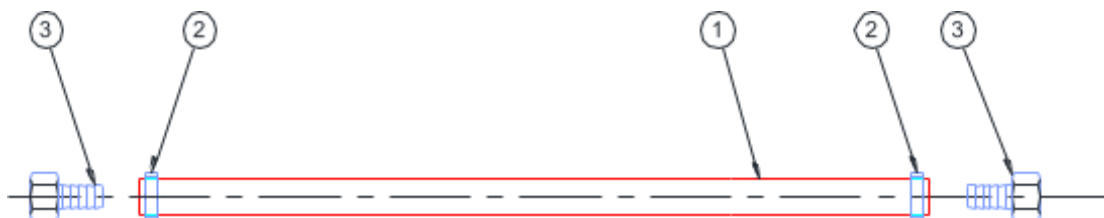

EXHAUST CONTROL LINE			MODEL	MultiBlast PRO 45
			ASSY NO.	
ITEM	DESCRIPTION	QTY		
1	AIRLINE - 1/4" (6MM) ID	0.4		
2	HOSE CLIP	2		
3	NUT & TAIL - 1/4" BSP FEMALE X 1/4" (6MM) BARB	2		

8.10 Pusher Line

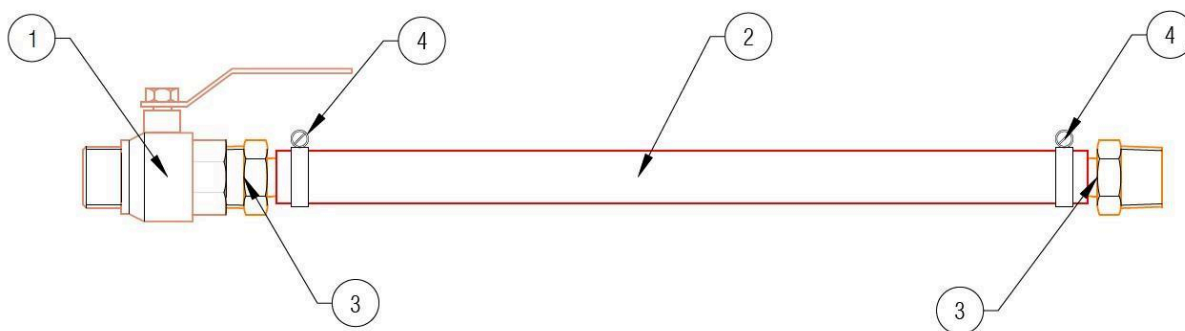

PUSHER LINE			MODEL	MultiBlast PRO 45
			ASSY NO.	A201284
ITEM	DESCRIPTION	QTY	PART NO.	
1	BALL VALVE - M & F - 1/2" BSP	1	V201461	
2	AIR HOSE - 1/2" ID	0.7	AHVPC13	
3	HOSE BARB - 1/2" BSP x 1/2"	2	B201857	
4	CLAMP - WORM DRIVE - 12-22mm	2	12-22/12W1P-50	

8.11 Mini Micro Abrasive Valve

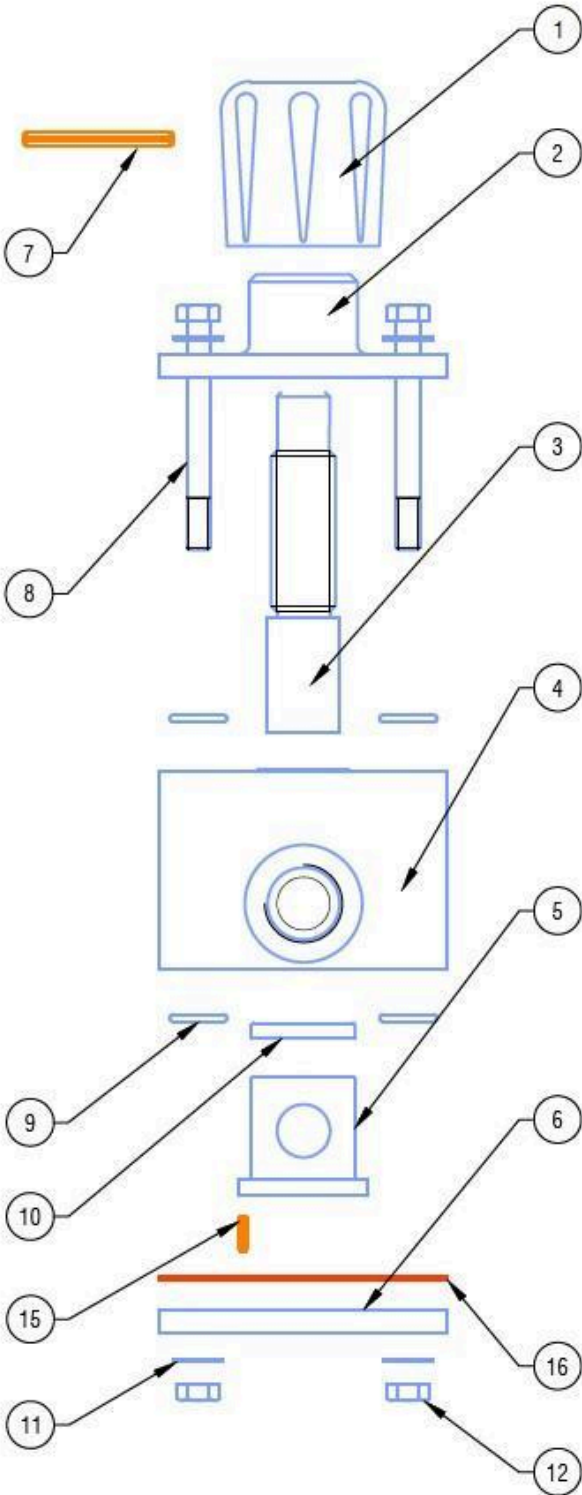

MINI MICRO VALVE – 3/4"		MODEL	MultiBlast PRO 45
		ASSY NO.	
ITEM	DESCRIPTION	QTY	
1	CONTROL KNOB	1	
2	VALVE CAP - TOP	1	
3	PLUNGER	1	
4	VALVE BODY – 3/4"	1	
5	SLEEVE	1	
6	VALVE CAP - BOTTOM	1	
7	ROLL PIN – 5mm x 50mm	1	
8	BOLT – HEX HEAD – M8 x 90	4	
9	O RING – 13.94 x 2.62	4	
10	LIP SEAL – 35 x 25 x 5	1	
11	NUT – HEXAGON – M8	2	
12	WASHER – FLAT – M8	1	
15	ROLL PIN – 2.5mm x 12mm	1	
16	GASKET	1	

8.12 Mini Micro Valve Service Kits

SERVICE KIT-MINI MICRO VALVE-3/4"		MODEL	MultiBlast PRO 45
		ASSY NO.	
ITEM	DESCRIPTION	QTY	
3	PLUNGER	1	
5	SLEEVE	1	
7	ROLL PIN – 5mm x 50mm	1	
9	O RING – 13.94 x 2.62	4	
10	LIP SEAL – 35 x 25 x 5	1	
15	ROLL PIN – 2.5mm x 12mm	1	
16	GASKET	1	

8.13 Twinline Assembly

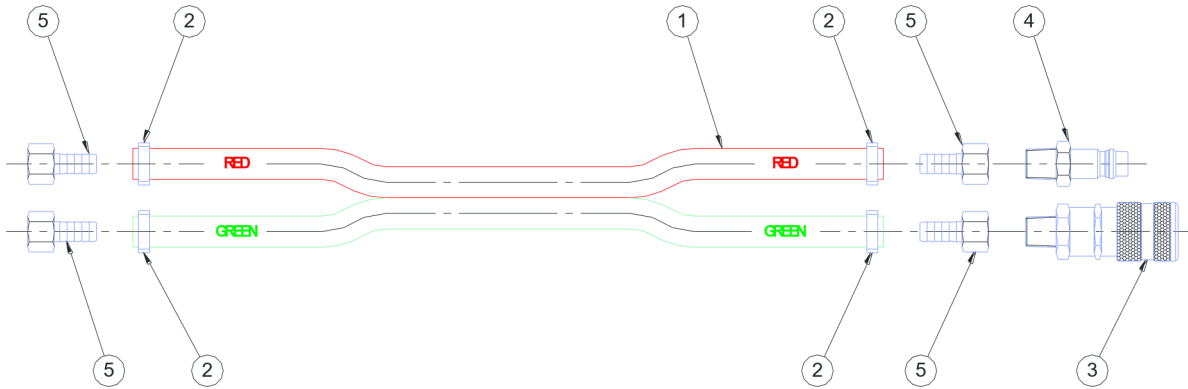

TWINLINE HOSE ASSEMBLY

		MODEL	MultiBlast PRO 45
		ASSY NO.	
ITEM	DESCRIPTION	QTY	
1	DEADMAN TWINLINE HOSE 6mm I/D	12	
2	O-CLIP (11mm - 13mm)	4	
3	TWO ACTION FEMALE COUPLING C/W 1-4" BSP MALE FITTING	1	
4	TWO ACTION MALE ADAPTOR C/W 1-4" BSP MALE FITTING	1	
5	NUT & TAIL 1-4" BSP FEMALE x 6 NB BARB	4	

8.14 Filter/Regulator Assembly

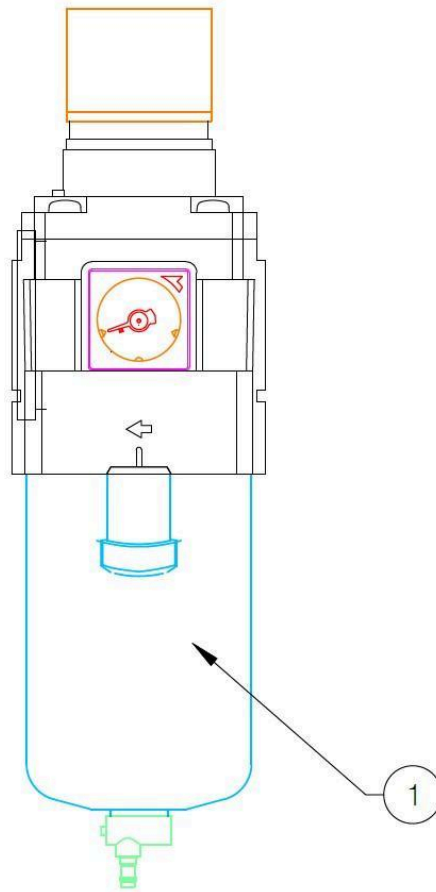

MOISTURE TRAP ASSEMBLY		MODEL	MultiBlast PRO 45
		ASSY NO.	
ITEM	DESCRIPTION	QTY	
1	REPLACEMENT BOWL ASSEMBLY	1	

8.15 Deadman Handle Assembly

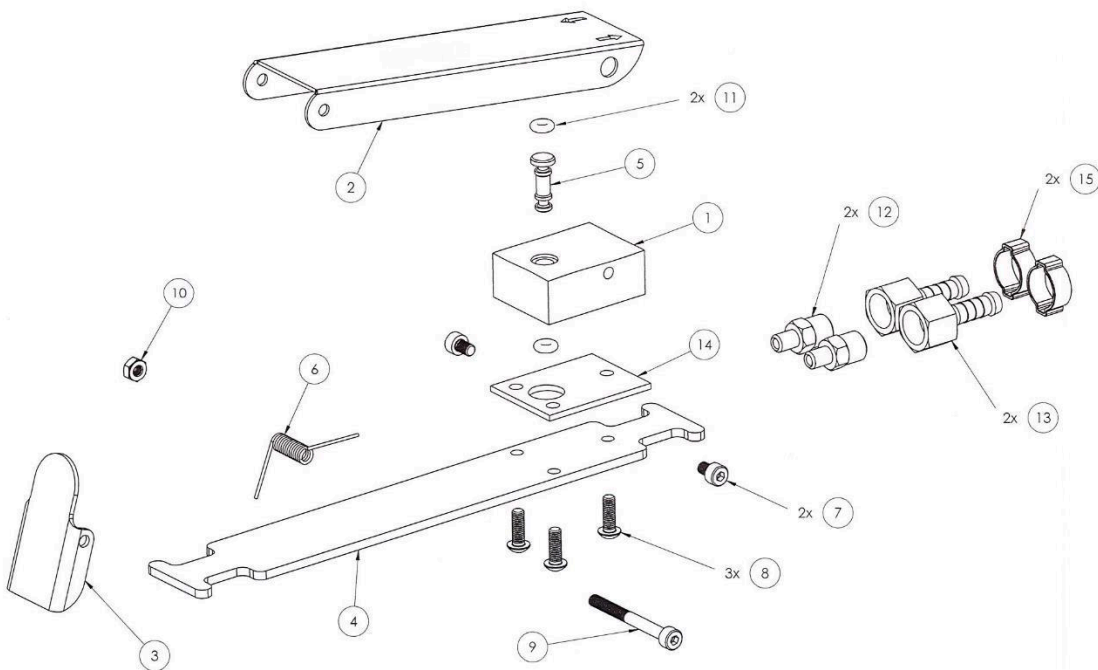
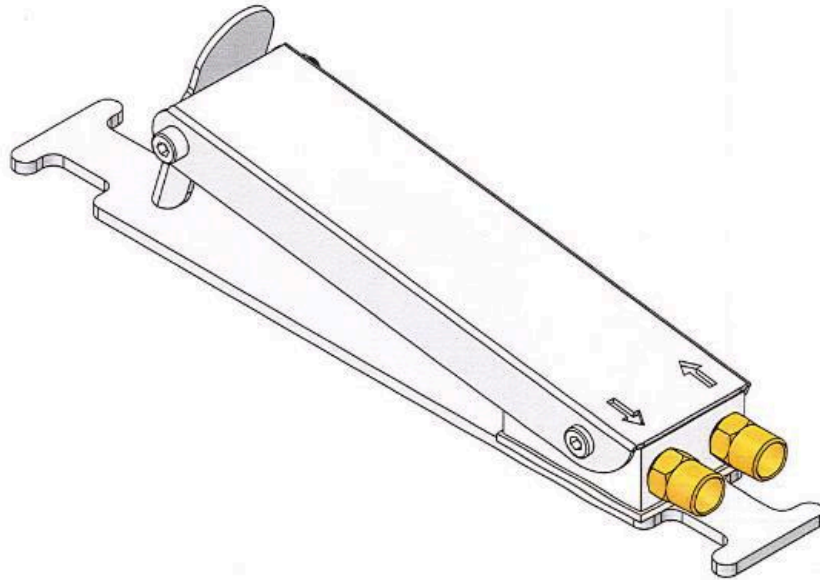

DEADMAN HANDLE ASSEMBLY			MODEL	MultiBlast PRO 45
			ASSY NO.	
ITEM	DESCRIPTION	QTY		
1	BODY	1		
2	HANDLE	1		
3	SAFETY LATCH	1		
4	BASEPLATE	1		
5	SPOOL	1		
6	SPRING	1		
7	SCREW-SOCKET HEAD-M4 X 6MM	2		
8	SCREW-BUTTON HEAD-M4 X 12MM	3		
9	SCREW-SOCKET HEAD-M4 X 40MM	1		
10	NUT-NYLOC-M4	1		
11	O RING	2		
12	NIPPLE-REDUCING-BRASS-1/4" BSP X 1/8" BSP	2		
13	NUT & TAIL	2		
14	GASKET	1		
15	O CLAMP	1		

DEADMAN SERVICE KIT			MODEL	MultiBlast PRO 45
			ASSY NO.	
ITEM	DESCRIPTION	QTY		
5	SPOOL	1		
8	SCREW-SOCKET HEAD-M4 X 12MM	3		
11	O RING	2		
14	GASKET	1		